

Hooded Tank Vent
KITO® BEH-4-IIB1-...-K
KITO® BEH-5-IIB1-...-K

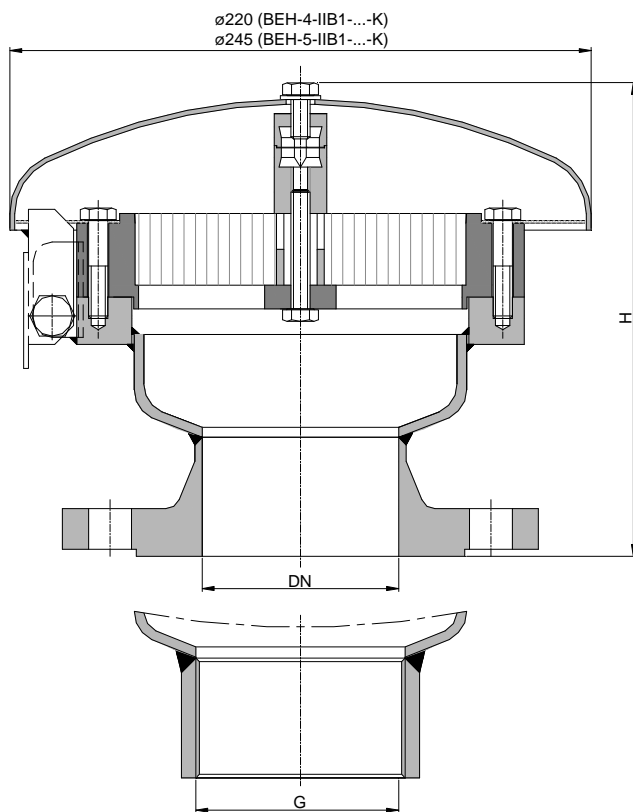
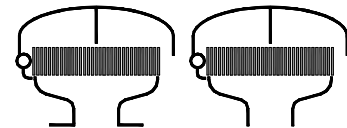

Example to order :

KITO® BEH-4-IIB1-25-K
 (design with flange connection DN 25)

Type examination certificate to DIN EN ISO 16852 and

CE -designation in accordance to ATEX-Guideline 94/9/EC in preparation

DN	ANSI	G	H		weight * (kg)	
			BEH-4-IIB1-...-K	BEH-5-IIB1-...-K	BEH-4-IIB1-...-K	BEH-5-IIB1-...-K
25 PN 40	1"	1"	184	197	8.5	10.5
32 PN 40	1 ¼"	1 ¼"	184	197	9.0	11
40 PN 40	1 ½"	1 ½"	196	199	9.5	11.5
50 PN 16	2"	2"	189	199	10	12
65 PN 16	2 ½"	2 ½"	189	200	10	14
80 PN 16	3"	3"	189	200	11	15
100 PN 16	4"	4"	-	200	-	15.5

Dimensions in mm

* weight refers to the standard design

Design subject to change

performance curves: B 0.1.2 N

Standard-design

- housing : steel, stainless steel mat. no. 1.4571
- KITO® flame arrester element : completely interchangeable
- KITO® casing / grid : stainless steel mat. no. 1.4308 / 1.4310, 1.4408 / 1.4571
- weather hood : stainless steel mat. no. 1.4571, hood can fold automatically as a result of folding mechanism and fusing element
- protective screen : PA6
- flange connection : DIN EN 1092-1 form B1, threaded format, ANSI 150 lbs. RF

Application

Deflagration and endurance burning proof venting hood for methanol, ethanol and 2-propanol under certain conditions of use.
 The minimum flow rates for outbreathing are given in the installation, operating and maintenance instructions (IOM).
 Also suitable as deflagration proof venting hood at tanks for flammable media of explosion group IIB1 with a maximum experimental safe gap (MESG) ≥ 0.85 mm.

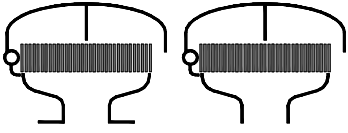

Hooded Tank Vent
KITO® BEH-4-IIB1-...-K
KITO® BEH-5-IIB1-...-K
B 1.2 N

Flow capacity V based on air of a density $\rho = 1,29 \text{ kg/m}^3$ at $T = 273 \text{ K}$ and atmospheric pressure $p = 1,013 \text{ mbar}$. For other gases the flow can be approximately calculated by

$$\dot{V} = \dot{V}_b \cdot \sqrt{\frac{\rho_b}{1.29}} \text{ or } \dot{V}_b = \dot{V} \cdot \sqrt{\frac{1.29}{\rho_b}}$$

KITO® BEH-4-IIB1-...-K

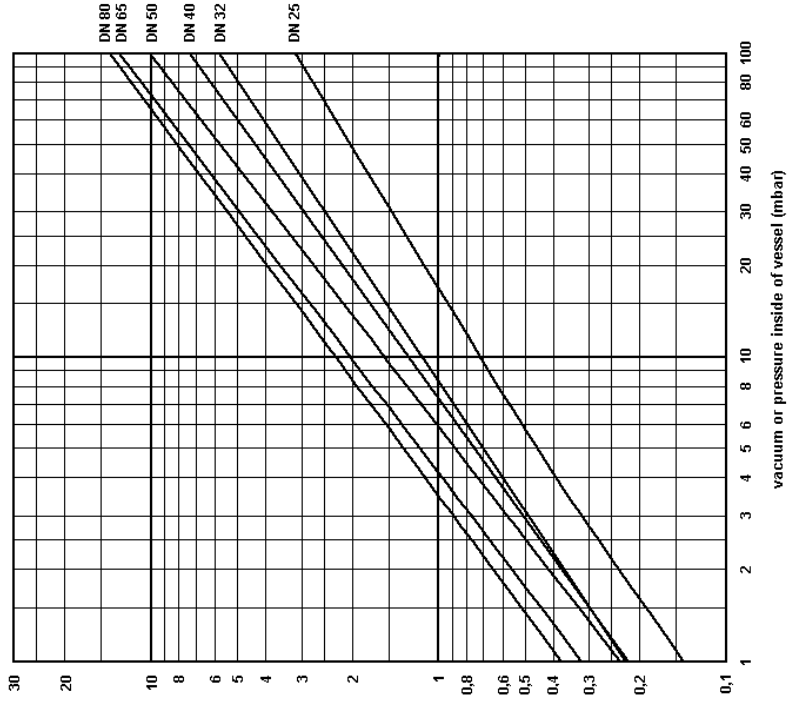

KITO® BEH-5-IIB1-...-K

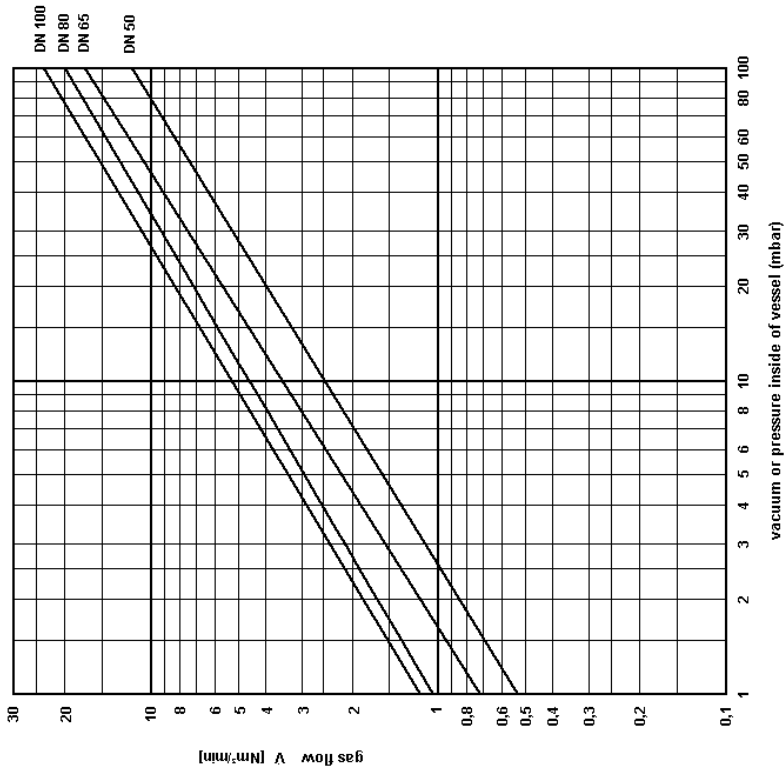

Design subject to change