

Combined Pressure / Vacuum Relief Valve KITO® VD/o

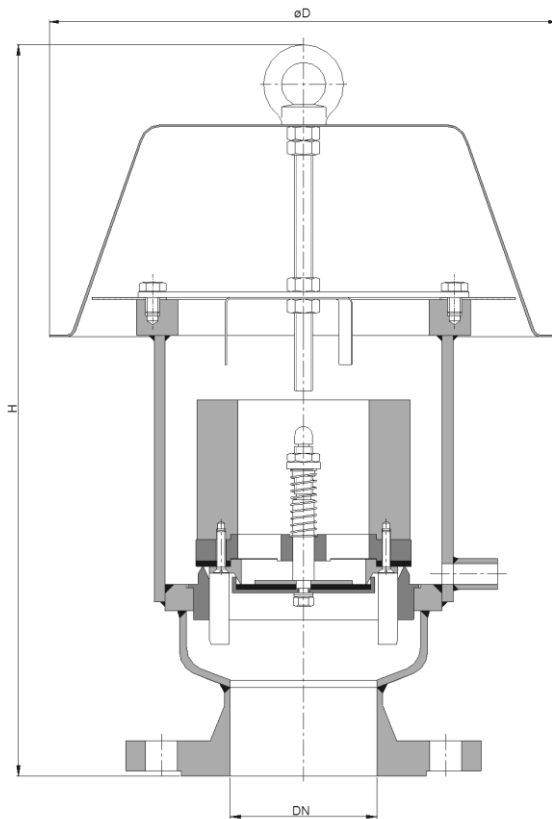
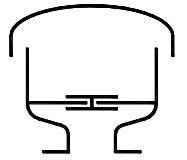

Without EC certificate and $\text{C}\epsilon$ -designation

DN		D	H		kg*	setting (mbar)			
DIN	ANSI		DIN	ANSI		vacuum		pressure	
						min.	max.	min.	max.**
50 PN 16	2"	220	332	351	11	3	50	10	75
80 PN 16	3"	260	367	387	14.5	3	50	10	70
100 PN 16	4"	260	368	393	17.8	3	50	10	80
125 PN 16	5"	405	435	499	22	3	50	10	80
150 PN 16	6"	405	445	537	31	3	50	10	77
200 PN 10	8"	450	553	595		3	50	10	55
250 PN 10	10"	600	600	635		3	50	10	100

Dimensions in mm

* Indicated weights are understood without weight load and refer to the standard design.

standard valve setting 10-30 mbar (pressure)
-different settings against additional price- (** higher settings require higher housings)

Design subject to change

performance curves: E 0.17 N

Standard design

housing : steel, mat. no. 1.4571
 valve parts / spindle : mat. no. 1.4571
 gasket : NBR, Viton, PTFE
 valve pallet (vacuum) : spring loaded
 valve pallet (pressure) : weight loaded
 weather hood : mat. no. 1.4301, mat. no. 1.4571,
 protective screen : PA6 (> DN 100 mat. no. 1.4301
 or 1.4571)
 flange connection : DIN EN 1092-1 form B1,
 ANSI 150 lbs. RF

Application

end-of-line armature, as breather and venting device, mainly used for tanks in which inflammable liquids are stored. Used to prevent inadmissible pressure or vacuum as well as gas losses or inadmissible emissions respectively. Valve is not explosion-proof on endurance-burning proof.