

Detonation flame arrester
KITO® FD6-Det4-IIB3-...-1.2

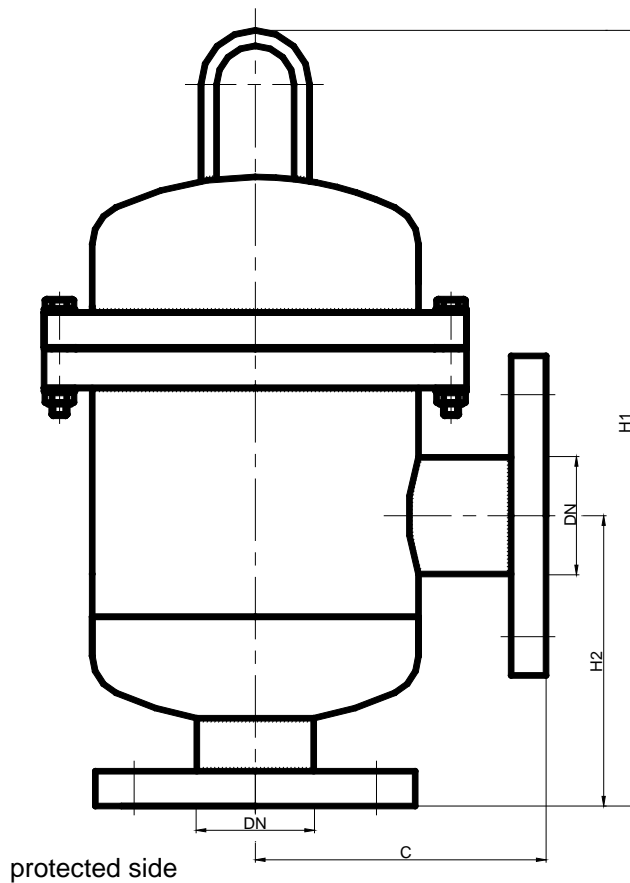
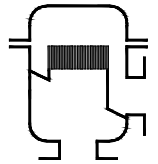

Example to order :
KITO® FD6-Det4-IIB3-50-1.2
 (Design DN 50 PN 16)

Type examination certificate to DIN EN ISO 16852 and C € -designation in accordance to ATEX-Guideline 94/9/EC in preparation!

DN	ANSI	C	H1	H2	kg*
50 PN 16	2"	215	585	215	54
65 PN 16	2 1/2"				56
80 PN 16	3"				57

Dimensions in mm

* weight refers to the standard design

Design subject to change

performance curves: G 0.20.5 N

Standard design

- housing / cover : steel, stainless steel mat. no. 1.4571
- gasket : HD 3822, PTFE
- KITO® flame arrester element : completely interchangeable
- KITO® casing / grid : stainless steel mat. no. 1.4571
- flange connections : DIN EN 1092-1 Form A, ANSI 150 lbs

Application

For installation into pipes to protect containers and components against **stable** detonation of flammable liquids and gases.
 Tested and approved as detonation flame arrester **type 4**.
 Approved for all substances of explosion groups IIA1 to IIB3 with a maximum experimental safe gap (MESG) ≥ 0.65 mm.
 Working unidirectional in pipes, whereby an operating pressure of 1.2 bar abs. and an operating temperature of 60°C must not be exceeded.
 The installation is not dependent on the position and both directions of flow are possible. During installation, please observe the direction of detonation and the indication „protected side“.