



KLINGER®
trusted. worldwide.

Nivåställ Transparent

Transparent Level Gauge

T50-D
T50-DG
T50-RAV 956/946
T50-RAV 957/947
PN 50 ANSI 300

Klinger T50: Nivåställ transparent för ånga och processapplikationer, lämplig för avstängningsventiler:

Mjuktätande avstängningsventiler Modell D (med packning) eller modell DG (med nipplar).

Metalltätande ventiler, RAV 956 (med nipplar) eller RAV 957 (roterbar) utvändigt gängad. Finns även med modell RAV 946/947, med invändig gänga.

Klinger T50: transparent level gauge for steam and process applications, suitable for shut-off fittings:

Soft sealed gauges cocks, model D (with packing) or model DG (with nipples).

Metal-to-metal sealed valves, RAV 956 (with nipples) or RAV 957 (rotatable), outside screwed types. Available also models RAV 946/947, inside screwed types.

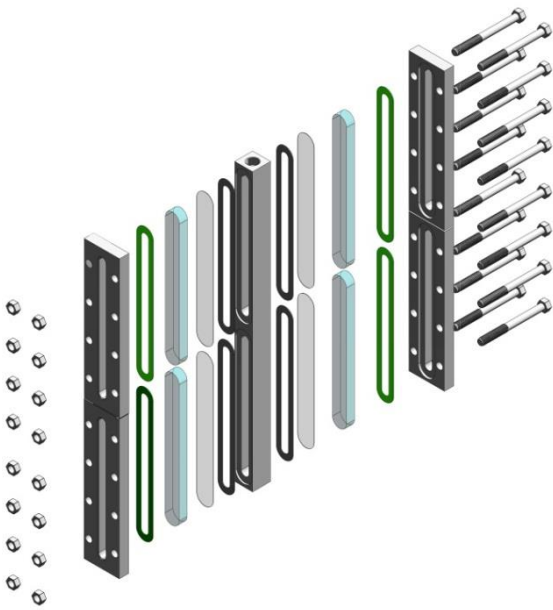

Tryck och temperatur

Working conditions

| | P max | T max |
|--------------------------|-----------------|-------|
| Ånga/steam (D) | 15 bar | 202°C |
| Process/process (DG-RAV) | PN 50/ ANSI 300 | 400°C |

Klinger materialkoder

Klinger material-codes

FS/H: Mediaberörda delar i kolstål
M/H: Mediaberörda delar i AISI316
M: Alla delar i AISI 316
(*) Andra material mot förfrågan

FS/H: components in carbon steel
M/H: components in contact with media in AISI 316
M: all components in AISI 316
(*) Other materials on request

Tillbehör

Accessories

Dränerings- och avluftningsventiler
Extern värme eller kylning
Frostskydd
Graderad skala
Belysning
Lamell typ Mica eller Kel-f

Drain/vent cocks
External heating or cooling
Non-frosting block
Graduated scale
Illuminator
Mica or Kel-shields

Enligt PED 2014/68/UE om tillämpligt
Compliance to PED 2014/68/UE when applicable

Enligt ATEX 2014/34/UE mot förfrågan
Compliance to ATEX 2014/34/UE upon request

Design och dimensioner kan ändras utan
förhandsinformation

Design and dimensions could be subject to
modification without notice



KLINGER
trusted. worldwide.

Nivåställ Transparent
Transparent Level Gauge

T50-D
T50-DG
T50-RAV 956/946
T50-RAV 957/947
PN 50 ANSI 300

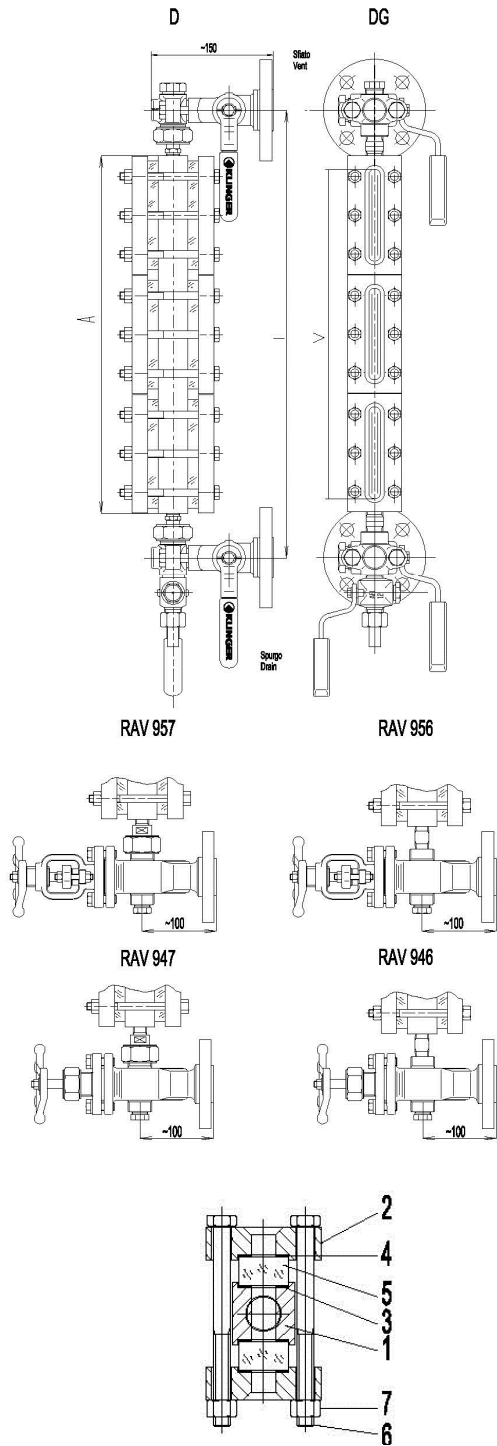

| Storlek | Längd Hus | Visningslängd (V) | Ca. Vikt | Minimum avstånd center till center (mm) (I) Minimum center to center distance (mm) (I) | | | |
|----------|-------------|-------------------|---------------|---|------|--------------------|--------------------|
| | | | | D | DG | RAV 956 RAV 946 | RAV 957 RAV 947 |
| Size | Body length | Sight length (V) | Approx weight | D | DG | RAV 956 RAV 946 | RAV 957 RAV 947 |
| | A | A-35 | Kg | A+102 | A+62 | A+97 | A+137 |
| I | 128 | 93 | 3,7 | 230 | 190 | 225 | 265 |
| II | 153 | 118 | 4,4 | 255 | 215 | 250 | 290 |
| III | 178 | 143 | 5,3 | 280 | 240 | 275 | 315 |
| IV | 203 | 168 | 6,0 | 305 | 265 | 300 | 340 |
| V | 233 | 198 | 6,9 | 335 | 295 | 330 | 370 |
| VI | 263 | 228 | 7,7 | 365 | 325 | 360 | 400 |
| VII | 293 | 258 | 8,5 | 395 | 355 | 390 | 430 |
| VIII | 333 | 298 | 9,7 | 435 | 395 | 430 | 470 |
| IX | 353 | 318 | 10,2 | 455 | 415 | 450 | 490 |
| 2 x IV | 408 | 373 | 12,0 | 510 | 470 | 505 | 545 |
| 2 x V | 468 | 433 | 14,0 | 570 | 530 | 565 | 605 |
| 2 x VI | 528 | 493 | 15,5 | 630 | 590 | 626 | 665 |
| 2 x VII | 588 | 553 | 17,1 | 690 | 650 | 685 | 725 |
| 2 x VIII | 668 | 633 | 19,6 | 770 | 730 | 765 | 805 |
| 2 x IX | 708 | 673 | 20,5 | 810 | 770 | 805 | 845 |
| 3 x VI | 793 | 758 | 23,3 | 895 | 855 | 890 | 930 |
| 3 x VII | 833 | 848 | 25,7 | 985 | 945 | 980 | 1020 |
| 3 x VIII | 1003 | 968 | 29,4 | 1105 | 1065 | 1100 | 1140 |
| 3 x IX | 1063 | 1028 | 30,8 | 1165 | 1125 | 1160 | 1200 |
| 4 x VII | 1178 | 1143 | 34,3 | 1280 | 1240 | 1275 | 1315 |
| 4 x VIII | 1338 | 1303 | 38,9 | 1440 | 1400 | 1435 | 1475 |
| 4 x IX | 1418 | 1383 | 41,1 | 1520 | 1480 | 1515 | 1555 |
| 5 x VII | 1473 | 1438 | 42,8 | 1575 | 1535 | 1570 | 1610 |
| 5 x VIII | 1673 | 1638 | 48,9 | 1775 | 1735 | 1770 | 1810 |
| 5 x IX | 1773 | 1738 | 51,4 | 1875 | 1835 | 1870 | 1910 |
| 6 x VIII | 2008 | 1973 | 58,7 | 2110 | 2070 | 2105 | 2145 |
| 6 x IX | 2128 | 2093 | 61,7 | 2230 | 2190 | 2225 | 2265 |
| 7 x VIII | 2343 | 2308 | 68,5 | 2445 | 2405 | 2440 | 2480 |
| 7 x IX | 2483 | 2448 | 72,0 | 2585 | 2545 | 2580 | 2620 |

| | Delar - Parts | Material - Materials* | | |
|---|------------------------|-----------------------|--------------|--------------|
| | | FS/H | M/H | M |
| 1 | Hus/level gauge body | ASTM A 105 | AISI 316 | AISI 316 |
| 2 | Front/cover | ASTM A 105 | ASTM A 105 | AISI 316 |
| 3 | Tätning/sealing gasket | GRAPHITE PSM | GRAPHITE PSM | GRAPHITE PSM |
| 4 | Packning/cushion joint | KLINGERSIL | KLINGERSIL | KLINGERSIL |
| 5 | Glas "B"/glass "B" | BOROSILICATE | BOROSILICATE | BOROSILICATE |
| 6 | Bultar/bolts | B7 | B7 | B8M |
| 7 | Muttrar/nuts | 2H | 2H | 8M |

Klinger Sweden AB
Kontovägen 3
SE-17562 Järfälla . Sverige
Tel. +46 (0)10 1998700
Fax. +46 (0)8 7392130
www.klinger.se