



KLINGER®
trusted. worldwide.

Nivåställ Transparent Transparent Level Gauge

TA120-DVK2

PN 250
120 bar
Mättad ånga
saturated steam

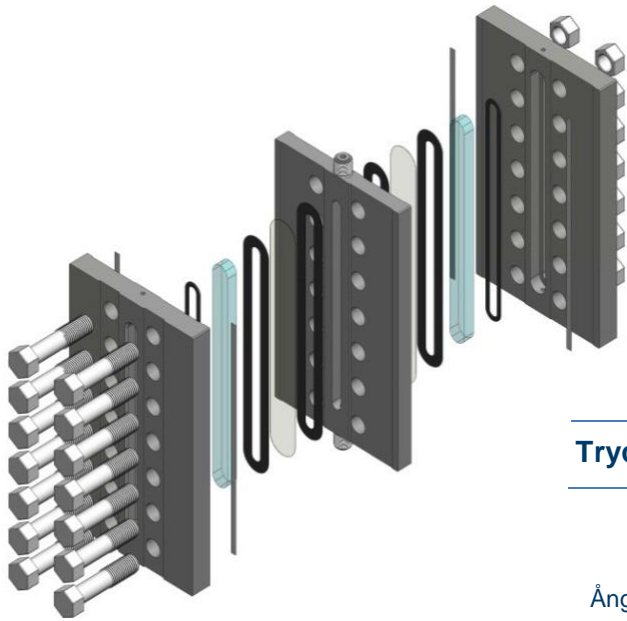

Klinger TA120: Nivåställ transparent för ånga, lämplig för avstängningsventiler:

Klinger TA120: transparent level gauge for steam applications, suitable for shut-off fittings:

Metalltätande DVK2.

Metal sealed valves DVK2.

Tryck och Temperatur

Working conditions

	P max	T max
Ånga/steam (DVK2)	120 bar	323° C

Klinger materialkoder

Klinger material-codes

FS/H: Mediaberörda delar i kolstål

FS/H: components in carbon steel

Tillbehör

Accessories

Dränerings- och avluftningsventiler

Drain/vent cocks

Extern värme eller kylning

External heating or cooling

Frostskydd

Non-frosting block

Graderad skala

Graduated scale

Belysning

Illuminator

Lamell typ Mica eller Kel-f

Mica or Kel-shields

Enligt PED 2014/68/UE om tillämpligt
Compliance to PED 2014/68/UE when applicable

Design och dimensioner kan ändras utan
förhandsinformation

Enligt ATEX 2014/34/UE mot förfrågan
Compliance to ATEX 2014/34/UE upon request

Design and dimensions could be subject to
modification without notice

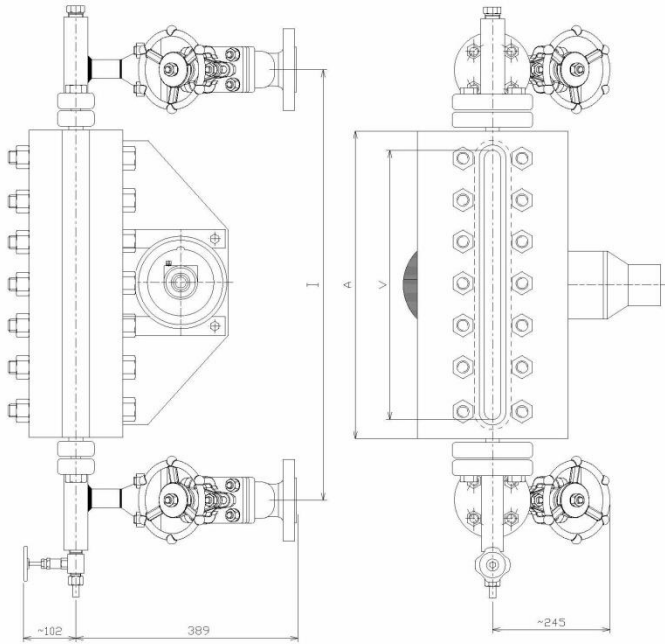

Storlek	Längd Hus	Visnings- längd	Ca. Vikt	Minimum avstånd center till center (mm)
Size	Body length	Sight length	Approx weight	Minimum center to center distance (mm)
	A	V	Kg	I min
III	220	145	30,00	353
IV	245	170	33,00	378
V	275	200	38,00	408
VI	305	230	44,00	438
VII	335	260	52,00	468
VIII	375	300	62,50	508
IX	395	320	69,50	528

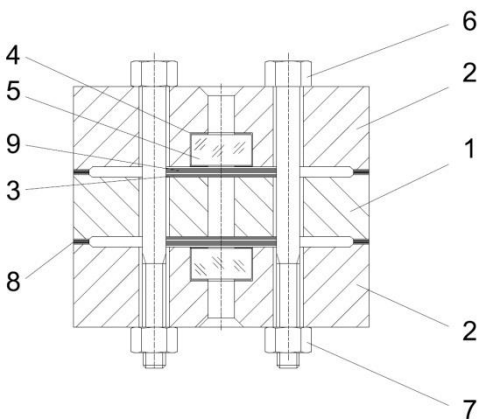

	Delar - Parts	Material - Materials
		FS/H
1	Hus/level gauge body	S355J2
2	Front/cover	S355J2
3	Lamell Mica / Mica Shield	MICA
4	Packning/cushion joint	GRAPHITE PSM
5	Glas "TA28"/ Glass "TA28"	BOROSILICATE
6	Bultar/bolts	8.8
7	Muttrar/nuts	CL10
8	Distans/Spacer strip	AISI 304
9	Tätning/Sealing gasket	GRAPHITE PDM